



Double push-butt.illum.no inscript.





Powering Business Worldwide™

Part no. M22-DDL-GR

Article no. 216698

Delivery programme

Product range			RMQ-Titan (drilling dimensions 22.5 mm)
Basic function			Double actuators
Single unit/Complete unit			Single unit
Description			White lens
Function			momentary
Design			Actuators and indicator lights non-flush
Button plate			 
Front ring			Front ring: titanium
Connection to SmartWire-DT			yes

Approbationen

UL approval	Yes
CSA approval	Yes
Product Standards	IEC/EN 60947-5; UL 508; CSA-C22.2 No. 14-05; CSA-C22.2 No. 94-91; CE marking
UL File No.	E29184
UL CCN	NKCR
CSA File No.	012528
CSA Class No.	3211-03
NA Certification	UL listed, CSA certified
Degree of Protection	UL/CSA Type 3R, 4X, 12, 13

General

Standards			IEC/EN 60947 VDE 0660
Lifespan, mechanical	Operations	x 10 ⁶	> 0.2
Operating frequency	Operations/h		≦ 3600
Actuating force		n	≦ 5
Protection type			IP66
Climatic proofing			Damp heat, constant to IEC 60068-2-78 Damp heat, cyclic to IEC 60068-2-30
Ambient temperature		°C	
Open		°C	- 25 - + 70
Storage		°C	- 40 - + 80
Mounting position			As required
Mechanical shock resistance		g	30 Shock duration 11 ms Sinusoidal according to IEC 60068-2-27
Indoor and protected outdoor installation			

Technical data ETIM 4.0

Lens design			Round
Number of locations			2

Protection type (IP), at front			IP66
Momentary			YES
Color button			-
Hole diameter		mm	22
Width of opening		mm	22
Design of button			flush
Color bezel			Chrome
With bezel			YES
Height meter opening		mm	6
Switching function latching			No
Suitable for illumination			YES
Material front ring			Insulated material

Dimensions

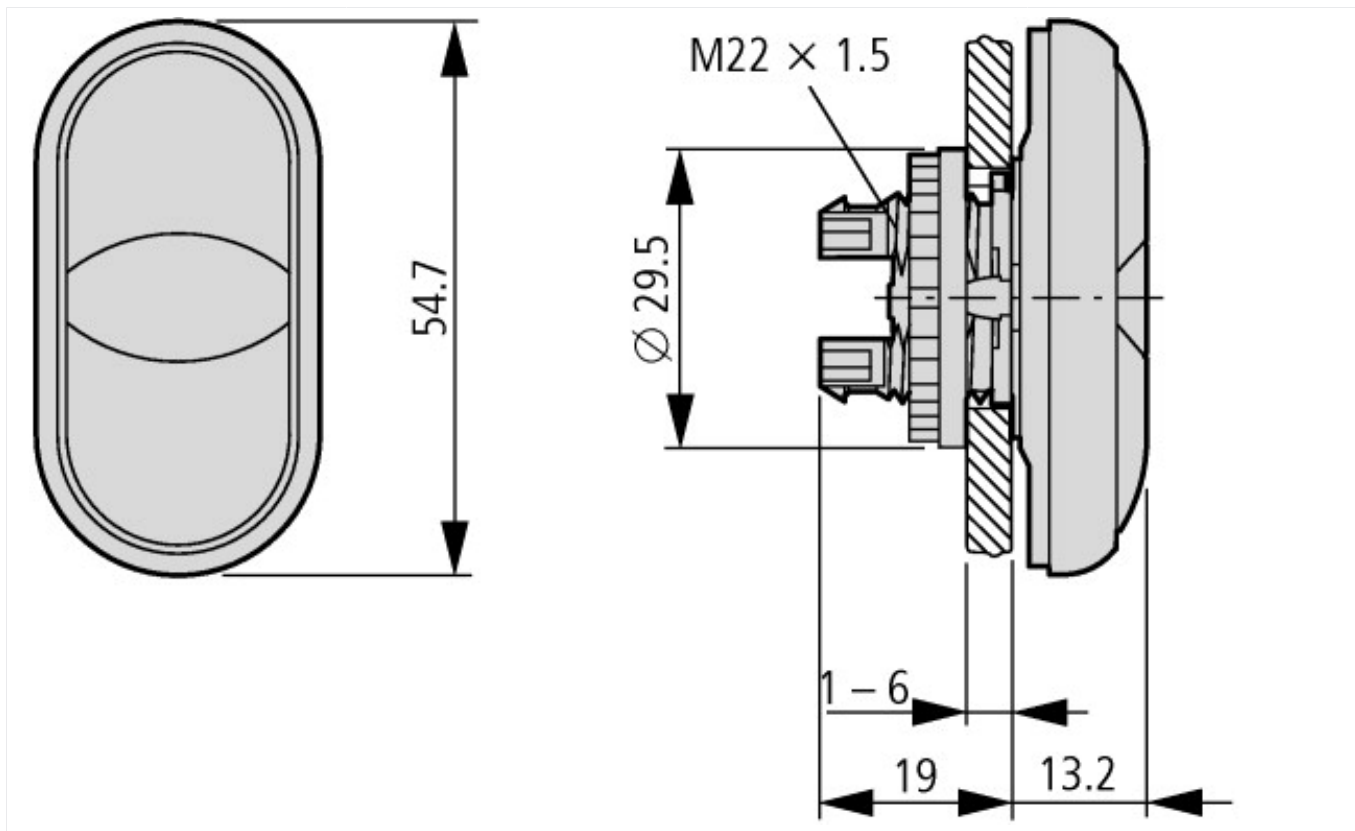

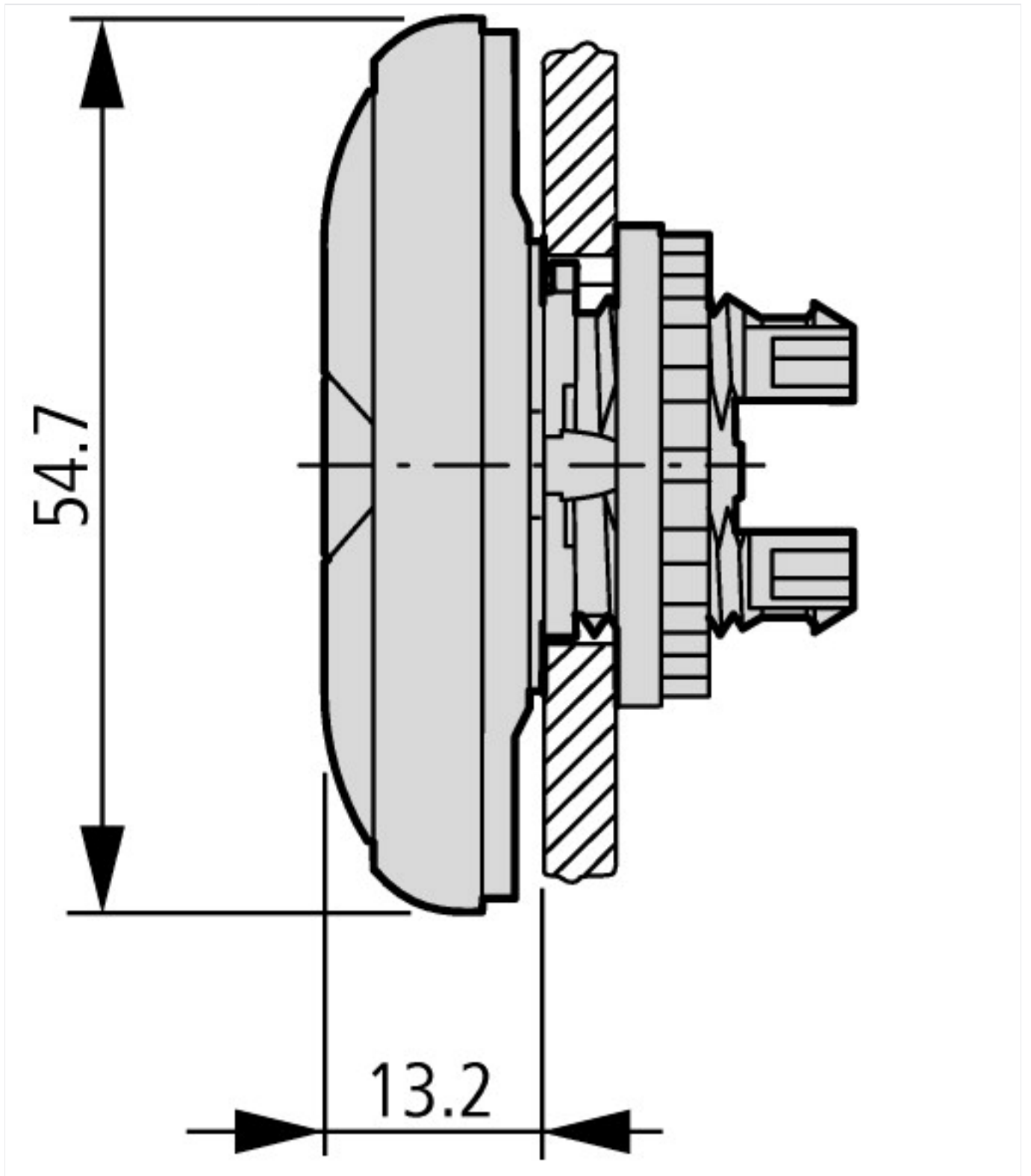

Additional product information (links)

IL04716002Z (AWA1160-1745) RMQ-Titan System

IL04716002Z (AWA1160-1745) RMQ-Titan System

ftp://ftp.moeller.net/DOCUMENTATION/AWA_INSTRUCTIONS/IL04716002Z2011_03.pdf

Labeleditor

ftp://ftp.moeller.net/MFD/EASY-SOFT-PRO/labeleditor_206.exe