



Emerg.stop/swit.off but.,non-ill.rot.rel

**EATON**

Powering Business Worldwide™

Part no. **M22-PVT**

Article no. **263467**

### Delivery programme

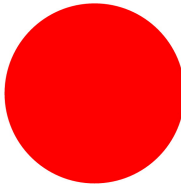
Product range			RMQ-Titan (drilling dimensions 22.5 mm)
Basic function			Emergency stop pushbutton/ emergency-stop button
Description			Turn to release
Construction type			Mushroom-shaped
Diameter	∅	mm	38
Colour			
Mushroom head			Red
RAL Value			RAL 3000
			
Illumination			Without illumination
Front ring			without front ring
Connection to SmartWire-DT			yes
<b>Instructions</b>			Release by turning
<b>Notes</b>			
Release by turning			
Button diameter 38 mm			

### Approbationen

UL approval	Yes
CSA approval	Yes
Product Standards	IEC/EN 60947-5; UL 508; CSA-C22.2 No. 14-05; CSA-C22.2 No. 94-91; CE marking
UL File No.	E29184
UL CCN	NKCR
CSA File No.	012528
CSA Class No.	3211-03
NA Certification	UL listed, CSA certified
Degree of Protection	UL/CSA Type 3R, 4X, 12, 13

### General

Standards			IEC/EN 60947 VDE 0660
Lifespan, mechanical	Operations	x 10 <sup>6</sup>	> 0.1
Operating frequency	Operations/ h		≦ 600
Actuating force		n	50
Protection type			IP67, IP69K
Climatic proofing			Damp heat, constant to IEC 60068-2-78 Damp heat, cyclic to IEC 60068-2-30
Ambient temperature		°C	
Open		°C	- 25 - + 70
Mounting position			As required
Mechanical shock resistance		g	50 Shock duration 11 ms Sinusoidal according to IEC 60068-2-27

### Technical data ETIM 4.0

With bezel			No
Unlocking method			Turn unlatching mechanism
Lens design			Round

Suitable for illumination		No
Hole diameter	mm	22
Suitable for emergency switching off		YES
Color button		red
Color bezel		Chrome
Width of opening	mm	22
Height meter opening	mm	6
Protection type (IP)		IP67
Material front ring		-
Diameter cap	mm	38
Momentary		No
Switching function latching		YES
Design of button		flush

## Dimensions

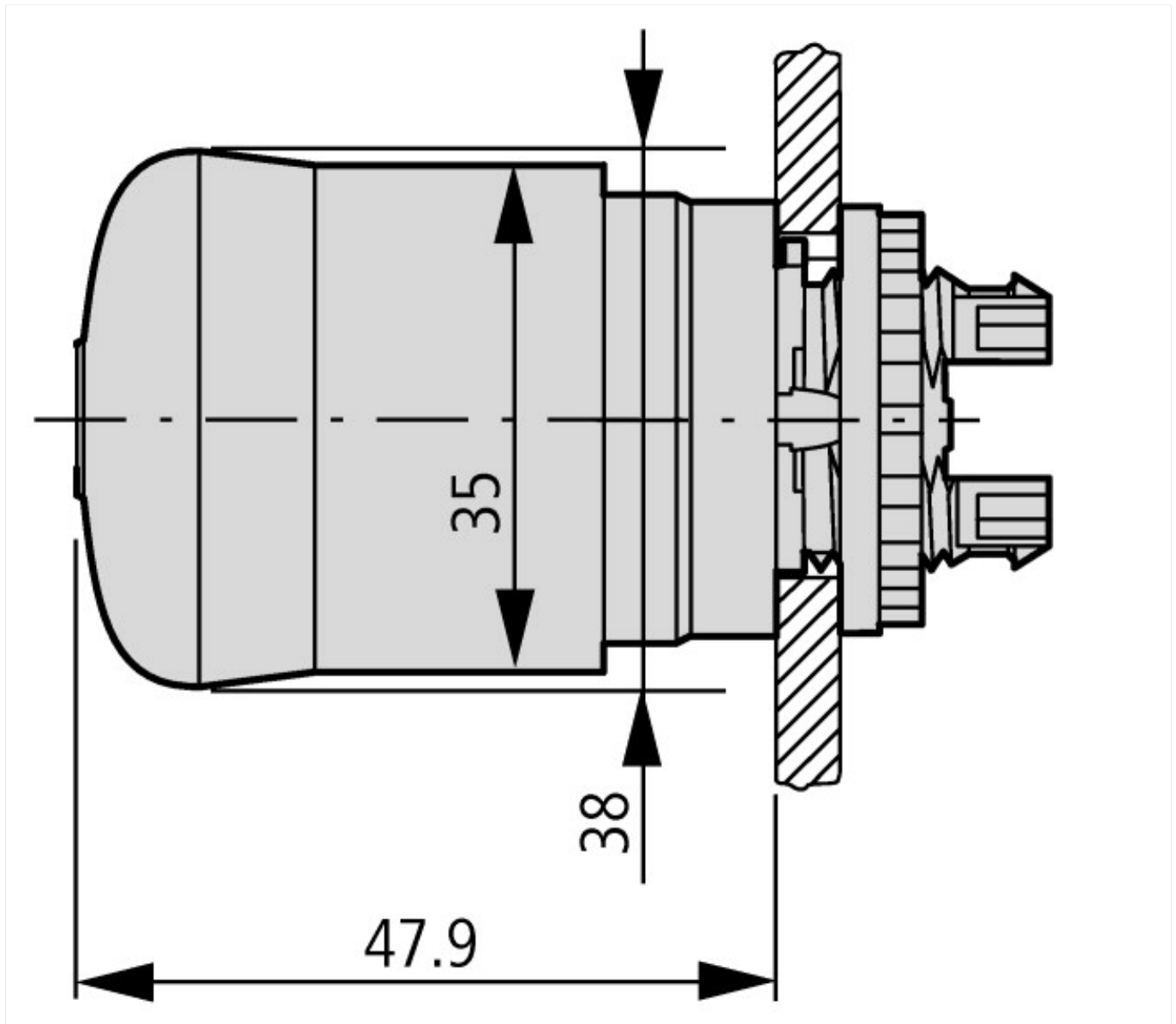

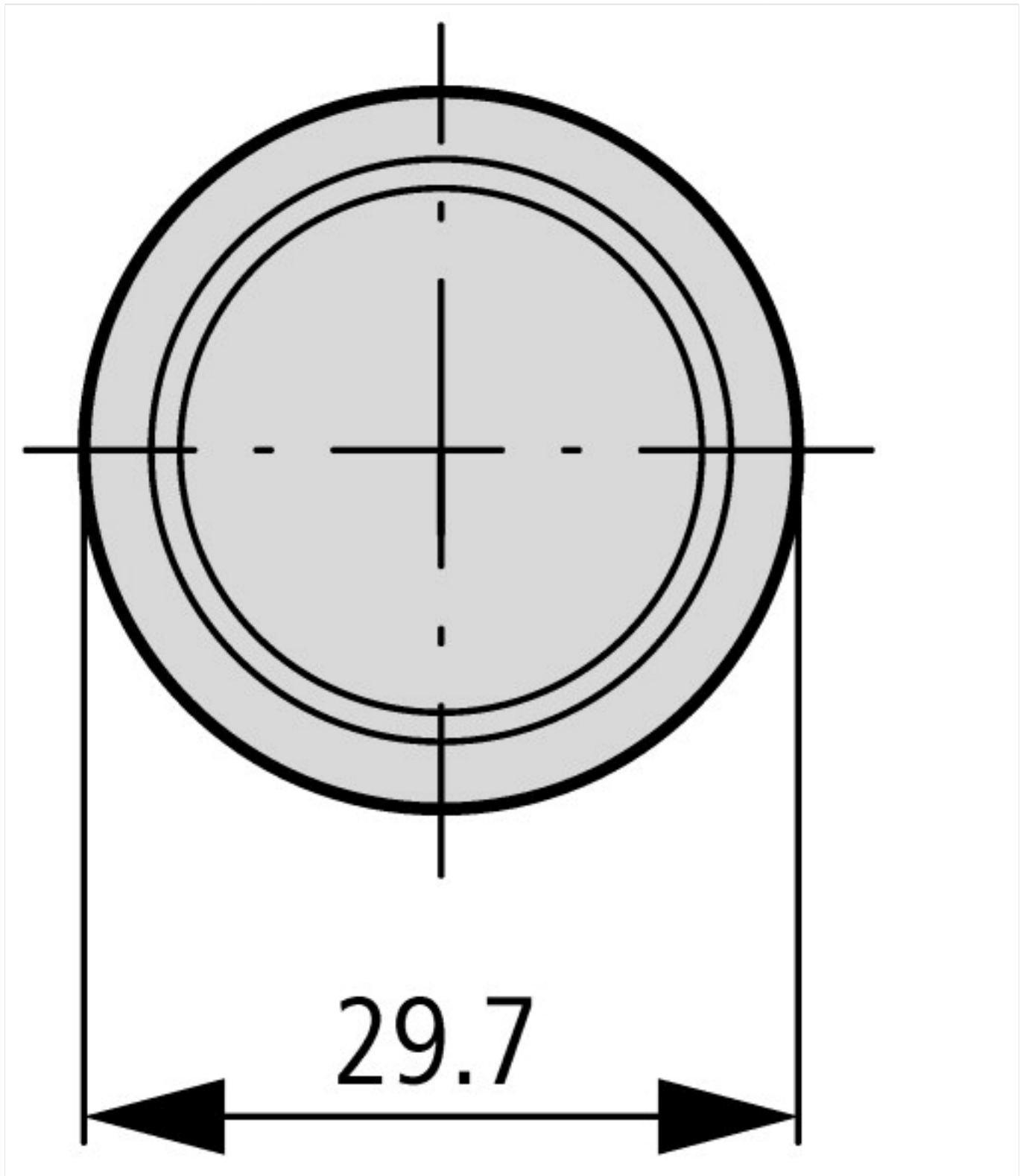

#### Additional product information (links)

IL04716002Z (AWA1160-1745) RMQ-Titan System

IL04716002Z (AWA1160-1745) RMQ-Titan System

[ftp://ftp.moeller.net/DOCUMENTATION/AWA\\_INSTRUCTIONS/IL04716002Z2011\\_03.pdf](ftp://ftp.moeller.net/DOCUMENTATION/AWA_INSTRUCTIONS/IL04716002Z2011_03.pdf)